

New HSCP module

with integrated LS priority function for hydraulic steering units (dynamic signal)

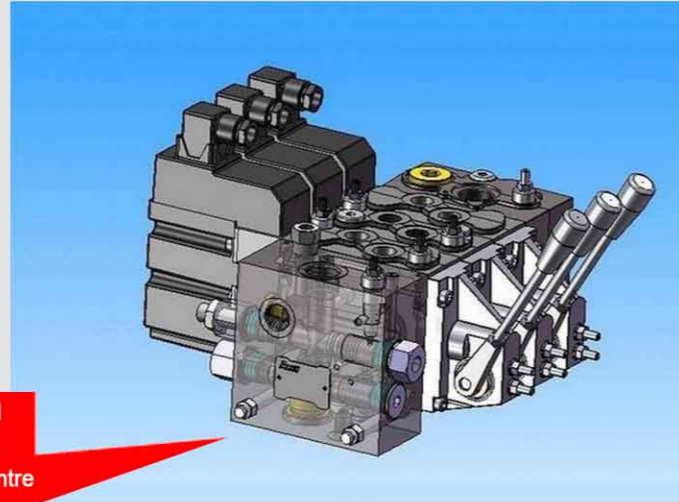

Designed to provide a priority flow to load sensing steering unit (LS dynamic signal), compatible with open centre or closed centre HSE pumps side modules, with flows up to 160 l/min

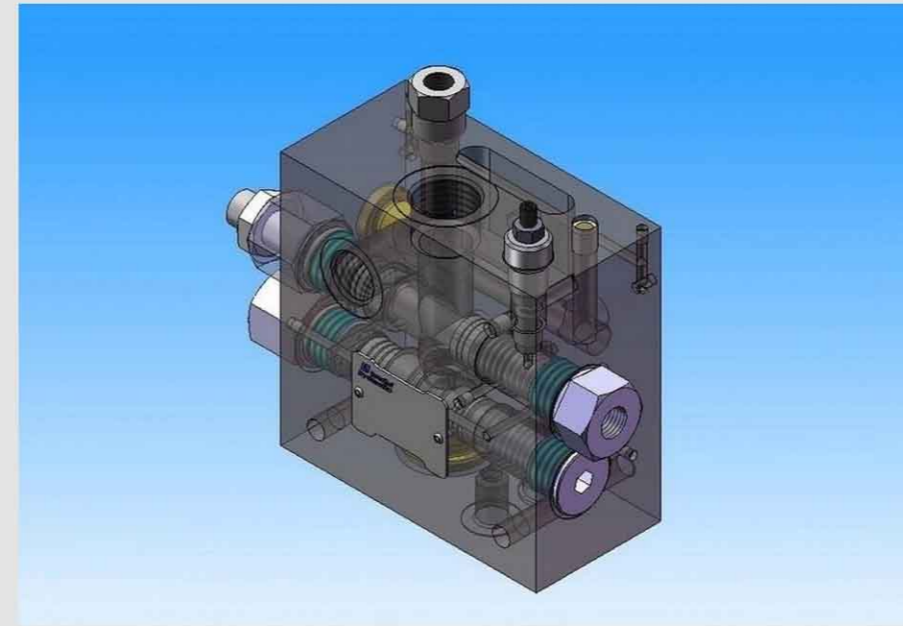

Max. pump pressure = 38 MPa
Max. pump flow = 160 l/min
Constant flow = up to 50 l/min

Compatible with open - centre or closed - centre HSE pump side modules



ordering code
no. HSCP004105030

Brevini Fluid Power S.p.A.
Via Moscova, 6
42124 Reggio Emilia
Italy
Tel +39 0522 270711
Fax + 39 0522 270660
info@brevinifluidpower.com
www.brevinifluidpower.com

brevini
fluid power
Meet your hydraulic needs easily

