

BC.06.25/27 P AND T REAR AND SIDE CONNECTORS 3/8" BSP - 2 RODS

- BC** Module base
- 06** CETOP 3/NG6
- \*\*** 25 = 3/8" BSP rear and side connectors with CMP  
27 = 3/8" BSP rear and side connectors without CMP
- \*** Adjustment (omit for 27 version)  
**M** = Plastic knob  
**C** = Grub screw
- \*** Setting range (omit for 27 version)  
**1** = max. 50 bar (**white spring**)  
**2** = max. 150 bar (**yellow spring**)  
**3** = max. 320 bar (**green spring**)
- 00** No variant
- 1** Serial No.

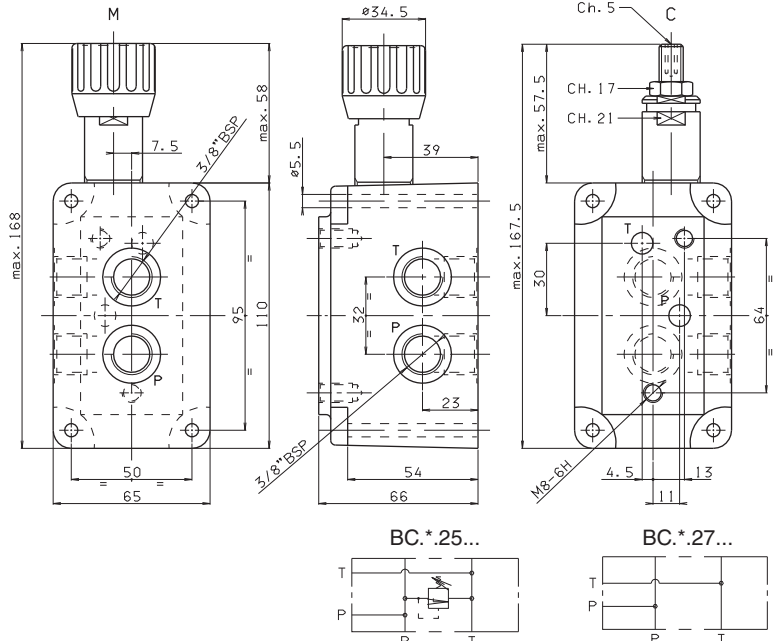

Weight BC.3.25 : 3 Kg  
 Weight BC.3.27 : 2,8 Kg  
 Fixing screws M5x65 UNI 5931

• The minimum permissible setting pressure depending on the spring:  
 see cartridge valve type CMP.10...

ASSEMBLED MODULAR COMPONENT BASES - 2 RODS

Rods code	L	Composition
BC.06.41/2 M80.20.0001	138	BC.06.25/27 + 2 BC.06.30/32 + BC.06.40
BC.06.41/3 M80.20.0002	187	BC.06.25/27 + 3 BC.06.30/32 + BC.06.40
BC.06.41/4 M80.20.0003	236	BC.06.25/27 + 4 BC.06.30/32 + BC.06.40
BC.06.41/5 M80.20.0004	285	BC.06.25/27 + 5 BC.06.30/32 + BC.06.40
BC.06.41/6 M80.20.0005	334	BC.06.25/27 + 6 BC.06.30/32 + BC.06.40
BC.06.41/7 M80.20.0006	382	BC.06.25/27 + 7 BC.06.30/32 + BC.06.40
BC.06.41/8 M80.20.0007	430	BC.06.25/27 + 8 BC.06.30/32 + BC.06.40
<b>Nuts code</b>	Q26.56.0514	
<b>Pieces</b>	2	

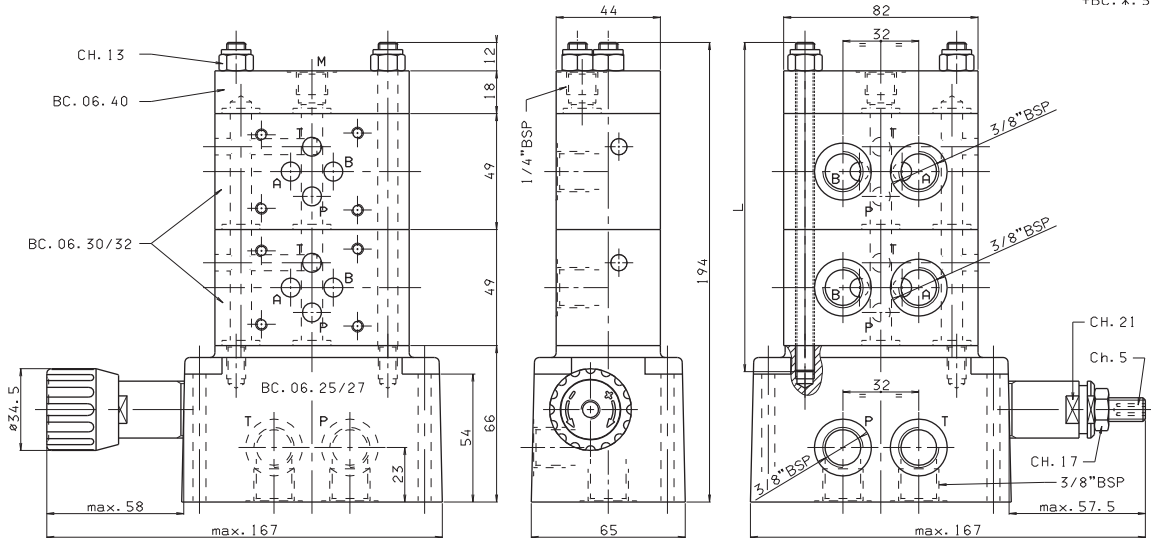
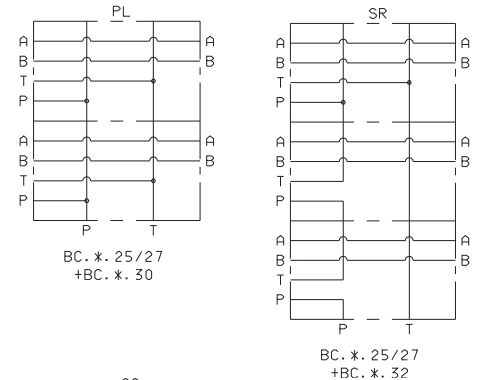

- For series connection the last block high up should be connected in parallel (BC.06.30)
- Single components should be ordered separately
- The minimum permissible setting range depending on the spring: see cartridge valve type CMP.10...

7

**BC.06.30/32 - 2 RODS**

- BC** Module base
- 06** CETOP 3/NG6
- \*\*** **30** = 3/8" BSP connectors in parallel  
**32** = 3/8" BSP connectors in series
- 00** No variant
- 1** Serial No.

Weight: 1,1 Kg

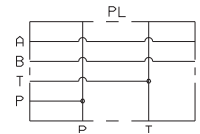
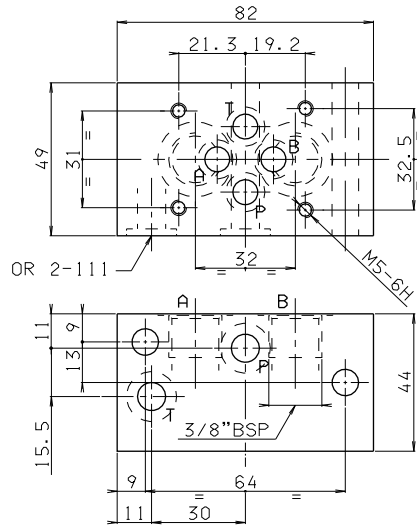

BC.\*.30...

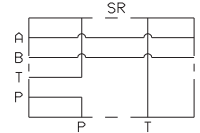

BC.\*.32...

**BC.06.40 - 2 RODS**

- BC** Module base
- 06** CETOP 3/NG6 - 2 rods
- 40** Blanking
- 00** No variant
- 1** Serial No.

Weight: 0,4 Kg

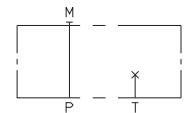
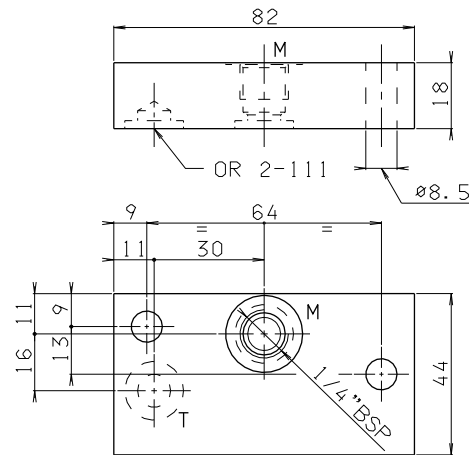

**BC.06.41/\* RODS FOR MODULAR ASSEMBLY**

Rod code	Pieces	L	Composition
BC.06.41/2.00.1	2	138	for 2 solenoid valves
BC.06.41/3.00.1	2	187	for 3 solenoid valves
BC.06.41/4.00.1	2	236	for 4 solenoid valves
BC.06.41/5.00.1	2	285	for 5 solenoid valves
BC.06.41/6.00.1	2	334	for 6 solenoid valves
BC.06.41/7.00.1	2	382	for 7 solenoid valves
BC.06.41/8.00.1	2	430	for 8 solenoid valves

