



BS.5... SINGLE STATION SUBPLATE



CETOP 5 SUBPLATES

BS.5.01 / BS.5.0*	CH. VII PAGE 19
BS.5.12... / BS.5.13...	
BS.5.14... / BS.5.15...	CH. VII PAGE 20
BS.5.16... / BS.5.17...	
BS.5.3...	CH. VII PAGE 21
BS.5.30/31...	CH. VII PAGE 22
BS.VMP.20... / BS.5.29...	CH. VII PAGE 23
BC.5.36/28...	CH. VII PAGE 24
BC.5.41*/... / BC.5.40...	CH. VII PAGE 25
BC.5.30/32... / BC.5.50... / BC.5.51...	CH. VII PAGE 26
BC.5.07... / BC.5.107...	
BC.5.3A... / BC.10.06...	CH. VII PAGE 27
BM.5.**... / BM.5.50...	CH. VII PAGE 28
BM.5.60... / BM.5.70...	
BM.5.80...	CH. VII PAGE 29
CMP.20...	BFP CARTRIDGE CATALOGUE
CMP.30...	BFP CARTRIDGE CATALOGUE

BS.5.01...

- BS** Single subplate (blanking)
- 5** CETOP 5/NG10
- 01** P/T/A/B closed
- 00** No variant
- 1** Serial No.

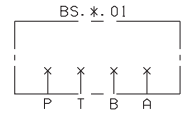

• Pay attention please, use these subplate in applications at slow pressure (P max. 150 bar dynamic)

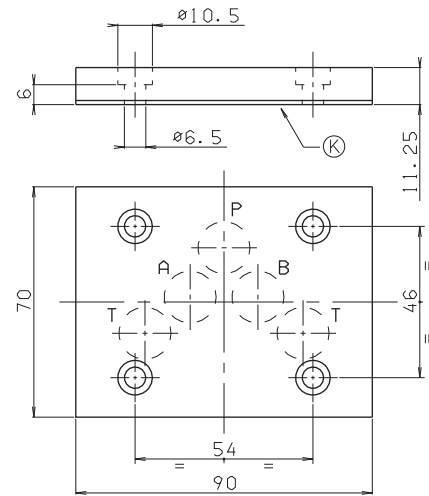

Weight: 0,5 Kg
 Fixing screws M6x15 UNI 5931
 K = plate OR (Q25.95.0002)

7

BS.5.**...

- BS** Single subplate (blanking)
- 5** CETOP 5/NG10
- **** 02/03/04/05/06/07/08/09
- 00** No variant
- 1** Serial No.

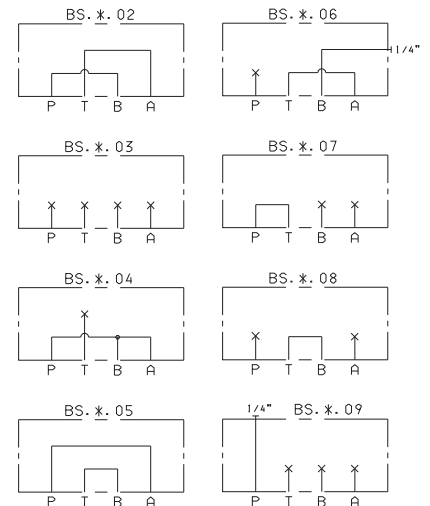
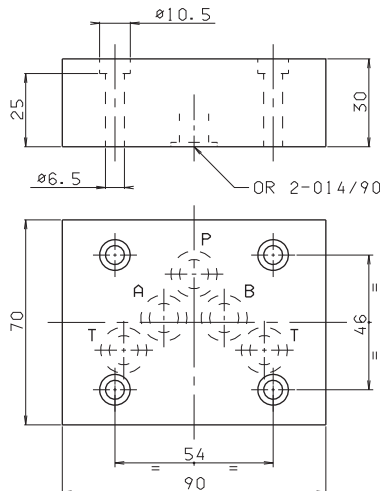

Weight: 1,2 Kg
 Fixing screws M6x35 UNI 5931

BS.5.12 (REAR CONNECTORS)

- BS** Single subplate
- 5** CETOP 5/NG10
- 12** 1/2" BSP rear connectors
- 00** No variant
- 1** Serial No.

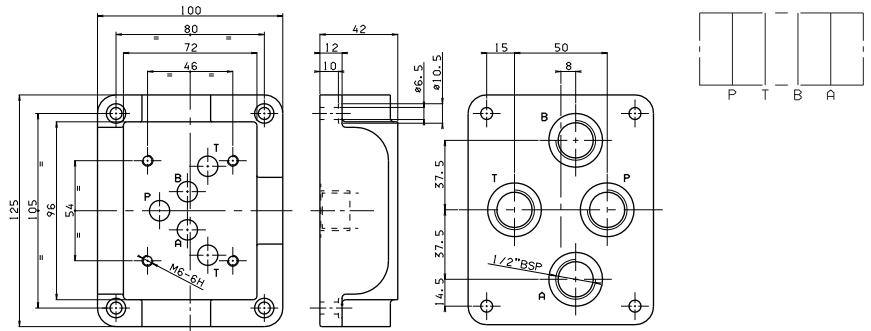

Weight: 2,7 Kg - Fixing screws M6x25 UNI 5931

BS.5.13 (REAR CONNECTORS)

- BS** Single subplate
- 5** CETOP 5/NG10
- 13** 3/4" BSP rear connectors
- 00** No variant
- 1** Serial No.

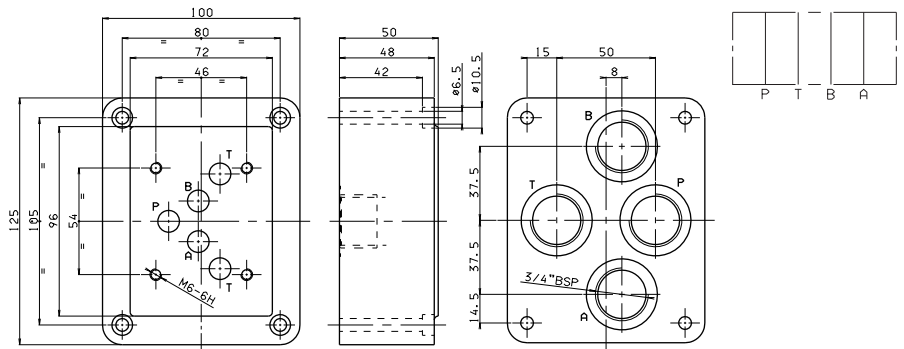

Weight: 3,8 Kg - Fixing screws M6x50 UNI 5931

7

BS.5.14 (SIDE CONNECTORS)

- BS** Single subplate
- 5** CETOP 5/NG10
- 14** 1/2" BSP side connectors
- 00** No variant
- 1** Serial No.

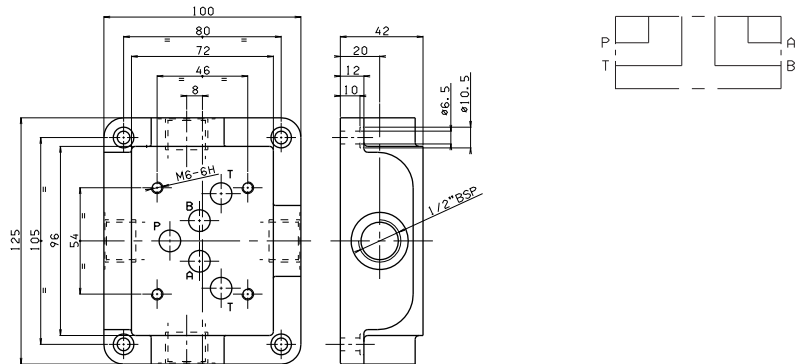

Weight: 2,6 Kg - Fixing screws M6x20 UNI 5931

BS.5.15 (SIDE CONNECTORS)

- BS** Single subplate
- 5** CETOP 5/NG10
- 15** 3/4" BSP side connectors
- 00** No variant
- 1** Serial No.

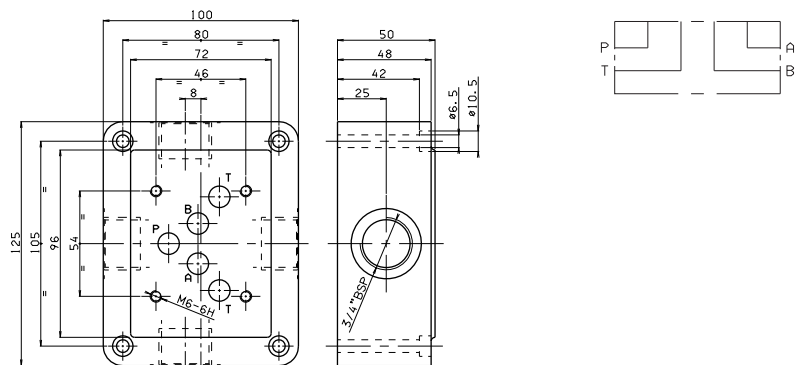

Weight: 3,8 Kg - Fixing screws M6x50 UNI 5931

BS.5.16 (CONNECTORS SIDE A AND B, REAR P AND T)

- BS** Single subplate
- 5** CETOP 5/NG10
- 16** 1/2" BSP rear and side connectors
- 00** No variant
- 1** Serial No.

Weight: 2,6 Kg
 Fixing screws M6x20 UNI 5931

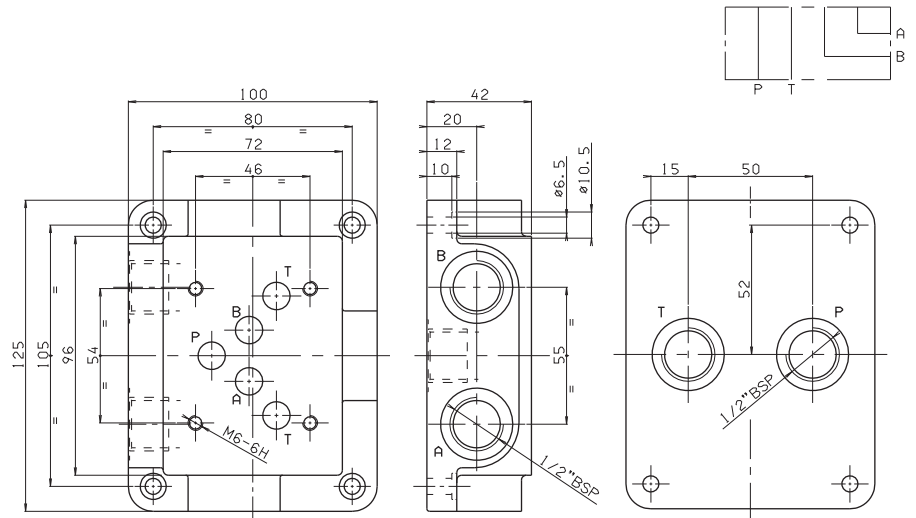

BS.5.17 (CONNECTORS SIDE A AND B, REAR P AND T)

- BS** Single subplate
- 5** CETOP 5/NG10
- 17** 3/4" BSP rear and side connectors
- 00** No variant
- 1** Serial No.

Weight: 3,9 Kg
 Fixing screws M6x50 UNI 5931

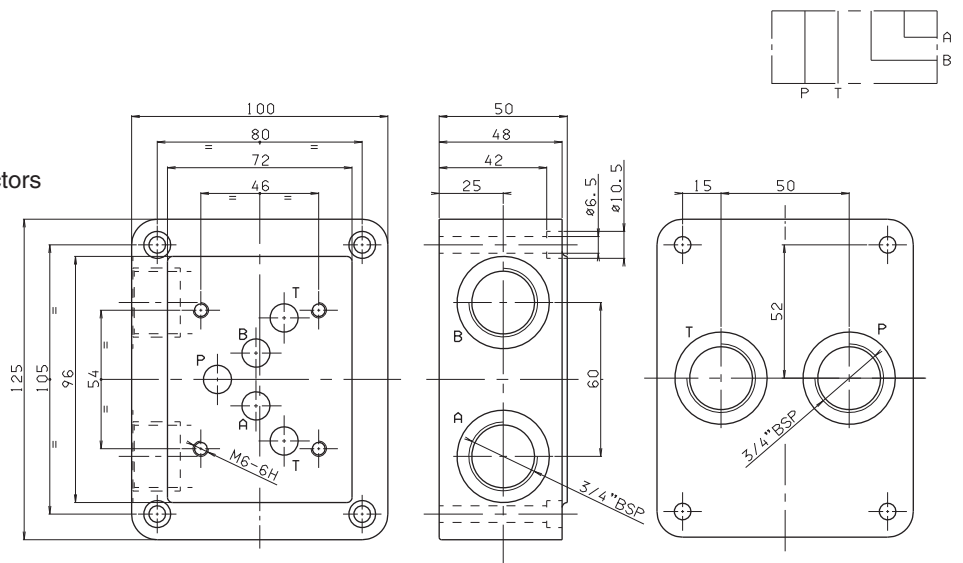

BS.5.3 (REDUCTION PLATE FROM CETOP 5/NG10 TO CETOP 3/NG6)

- BS** Single subplate
- 5** CETOP 5/NG10
- 3** CETOP 3/NG6
- 00** No variant
- 1** Serial No.

Weight: 1,1 Kg
 Fixing screws M6x30 UNI 5931

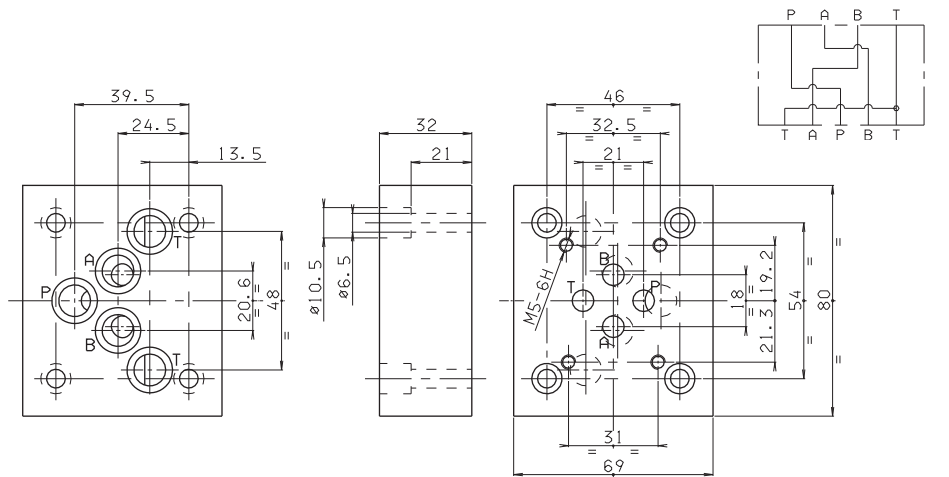

7

BS.5.30/31

- BS** Single subplate
- 5** CETOP 5/NG10
- **** **30** = Connectors A and B side, P and T rear (all 3/4" BSP)
31 = Connectors A and B side, P and T rear (all 3/4" BSP)
- *** **M** = Plastic knob
C = Grub screw
- *** Setting range
1 = max. 50 bar (**white spring**)
2 = max. 140 bar (**yellow spring**)
3 = max. 350 bar (**green spring**)
- 00** No variant
- 1** Serial No.

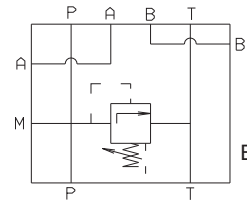

BS.5.30...

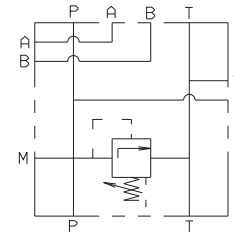

BS.5.31...

• The minimum permissible setting pressure depending on the spring:
see cartridge valve type CMP.30...

BS.5.30 (CONNECTORS A AND B SIDE, P AND T REAR)

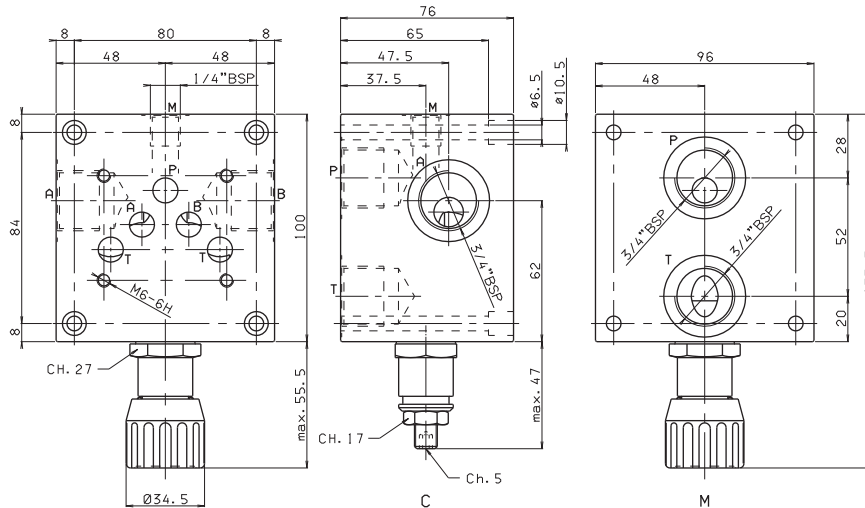

Weight: 5,5 Kg
Fixing screws
M6x75 UNI 5931

BS.5.31 (CONNECTORS A AND B SIDE, P AND T SIDE AND REAR)

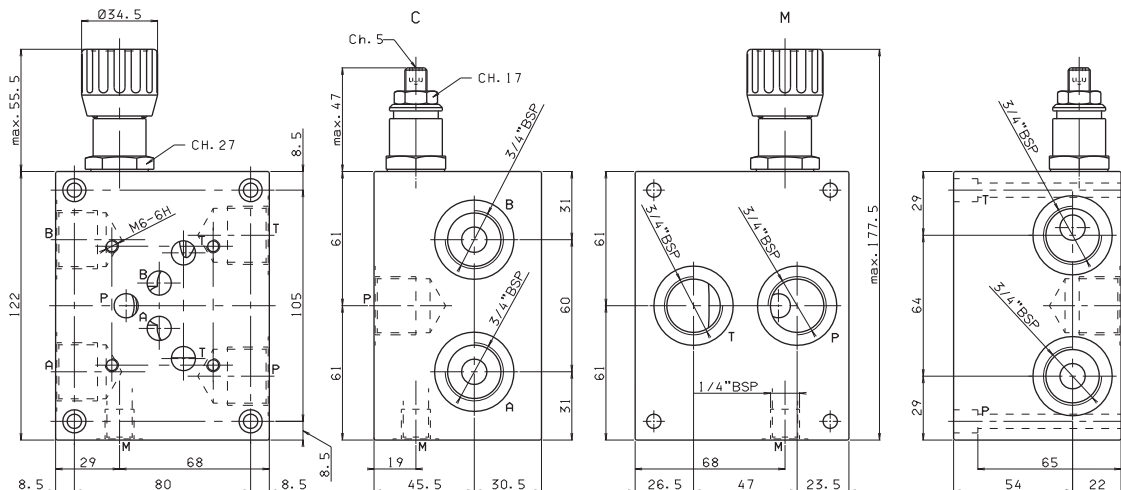

Weight: 6,7 Kg - Fixing screws M6x75 UNI 5931

7

BS.VMP.20 SINGLE STATION SUBPLATE WITH MAX. PRESSURE VALVE FOR SURFACE MOUNTING (E.G. ON TANK COVER)

- BS** Single subplate
- VMP** Max. pressure valve
- 20** 1/2" BSP connectors
- *** **M** = Plastic knob
C = Grub screw
V = Handwheel
- *** Setting range
1 = max. 50 bar (**white spring**)
2 = max. 140 bar (**yellow spring**)
3 = max. 250 bar (**green spring**)
- 00** No variant
- 1** Serial No.

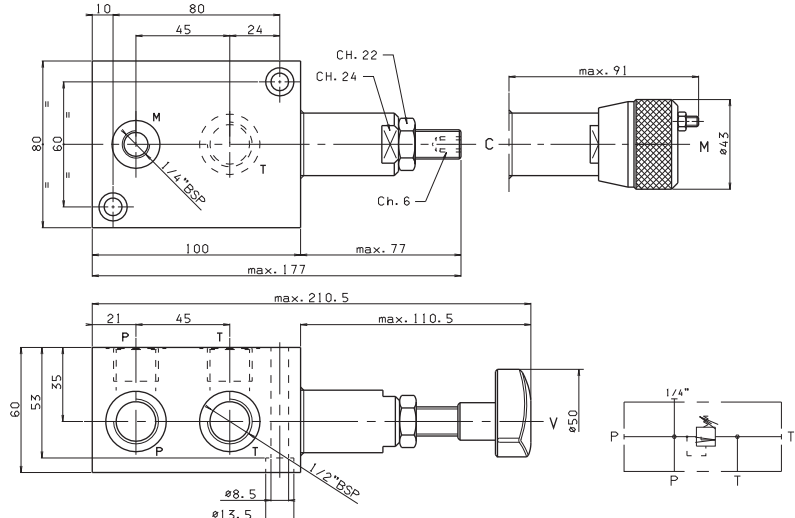

Weight: 3,1 Kg
Fixing screws M8x65 UNI 5931

• The minimum permissible setting pressure depending on the spring:
see cartridge valve type CMP.20...

BS.5.29 SINGLE STATION SUBPLATE WITH MAX. PRESSURE VALVE FOR AD.5.I...

- BS** Single subplate
- 5** CETOP 5/NG10
- 29** 1/2" BSP - P rear connector
1/2" BSP - A and B side connectors
1/2" BSP - T rear connector
3/4" BSP - T side connector
- C** Type of adjustment
Grub screw
- *** Setting range
2 = max. 150 bar (**yellow spring**)
3 = max. 320 bar (**green spring**)
- 00** No variant
- 1** Serial No.

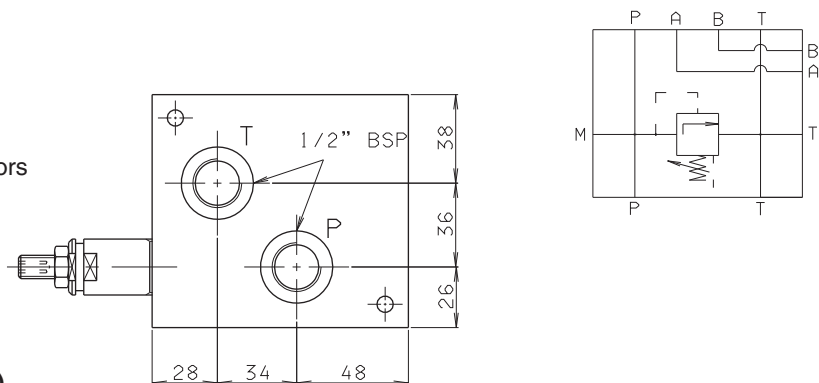

Weight: 4,5 Kg
Fixing screws M6x60 UNI 5931

Tightening torque CMP.10...
60 ÷ 70 Nm / 6 ÷ 7 Kgm

M = Manometer connector (1/4" BSP)

