



V*.P PRESSURE CONTROL VALVES PLATE
V*.L PRESSURE CONTROL VALVES IN LINE



These pressure control valves are available in the basic VMP* maximum pressure, VSP* sequence and VUP* exclusion versions, with a single pressure value and three calibration ranges that cover the band 15 ÷ 400 bar. It is possible to use auxiliary pilot valves, which can be the simple standard AD3E solenoid valve, by the mere exchange of covers. These valves have been fitted with an important safety feature for the operation of the system where they are used; a mechanical end of stroke stop prevents the operator from setting pressure values higher than those specified in the catalogue (it is impossible to compress the spring completely). In the standard configuration these valves are supplied with a 1.6 bar main spring and with calibrated ø1 mm pilot feed orifice (Variant part No. 00). Subplate mounting valves are suitable for covers which do not conform to DIN standards type C*P16/25.. whilst in line mounting valves are suitable for DIN standards covers type KEC16/25...

Pressure max.		400 bar
Setting ranges	Spring 1	15 ÷ 45 bar
	Spring 2	15 ÷ 145 bar
	Spring 3	45 ÷ 400 bar
Max. flow V*P16...		150 l/min
Max. flow V*P25...		350 l/min
Hydraulic fluids		Mineral oils DIN 51524
Fluid viscosity		10 ÷ 500 mm ² /s
Fluid temperature		-25°C ÷ 75°C
Ambient temperature		-25°C ÷ 60°C
Max. contamination level	class 10 in accordance with NAS 1638 with filter β ₂₅ ≥ 75	
Drainage V*P16...		1 ÷ 2 l/min
Drainage V*P25...		1 ÷ 2.5 l/min
Dynamic pressure at drainage		Max. 2 bar
Weight V*P16... (without pilot valve)		3,3 Kg
Weight V*P25... (without pilot valve)		7,4 Kg
Weight V*L16... (without pilot valve)		4,6 Kg
Weight V*L161... (without pilot valve)		4,5 Kg
Weight V*L251... (without pilot valve)		7,7 Kg
Weight V*L25... (without pilot valve)		8,3 Kg

V*.P / V*.L...

V*.P...	CH. II PAGE 7
V*.P.E...	CH. II PAGE 8
V*.L...	CH. II PAGE 9/10
BS.VMP...	CH. II PAGE 11
KEC.16/25...	CH. V PAGE 9
C*P.16/25...	CH. V PAGE 9
CETOP 3/NG06	CH. I PAGE 8
STANDARD SPOOLS FOR AD.3.E	CH. I PAGE 10
AD.3.E...	CH. I PAGE 11
AM.3.VM...	CH. IV PAGE 9

ORDERING CODE

V	Valve
*	M = maximum pressure S = sequence U = exclusion (areas rep. 1,15 : 1)
*	P = Plate mounting L = In line mounting
*	E = Presetting for solenoid valve Not for sequencing valve V.S.P... (omit if not required)
***	Size (see overall dimensions) 16 - 25 = NG16 or NG25 161 - 251 = for V*.L... only (in line mounting valve)
*	Type of adjustment: M = Plastic knob C = Grub screw
*	Setting ranges 1 = 15 ÷ 45 bar (white spring) 2 = 15 ÷ 145 bar (yellow spring) 3 = 45 ÷ 400 bar (green spring)
**	00 = No variant V1 = Viton AC = Exclusion valve for accumulators (only for VU*.**) AQ = Presetting for XP3
2	Serial No.

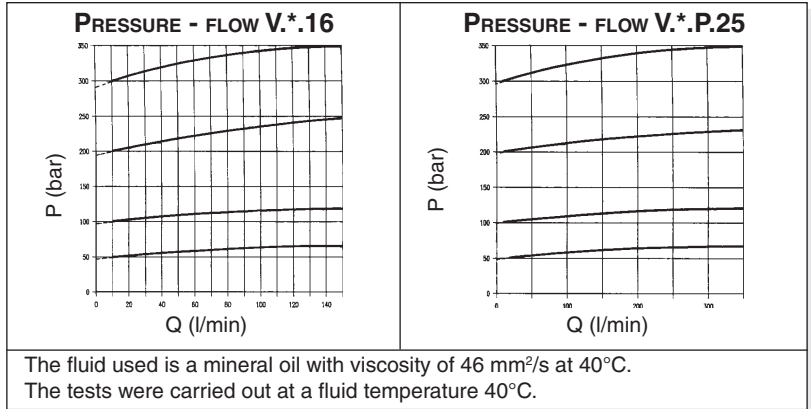

HYDRAULIC SYMBOLS

<p>V.M.P.16.**... V.M.P.25.**...</p> <p>Maximum pressure valve</p> <p>Internal piloting and draining</p>			
<p>V.S.P.16.**... V.S.P.25.**...</p> <p>Sequencing valve</p> <p>Internal piloting External draining</p>			
<p>V.U.P.16.**... V.U.P.25.**...</p> <p>Exclusion valve</p> <p>External piloting Internal draining</p>			

OVERALL DIMENSIONS V*.P.16...

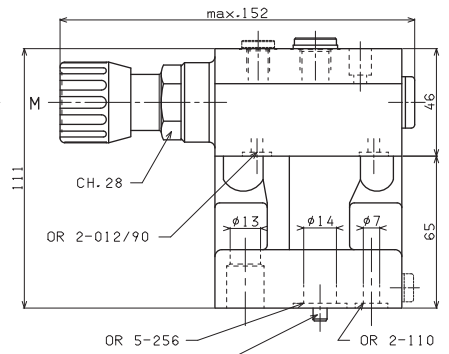
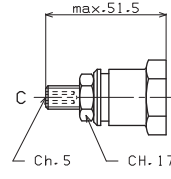
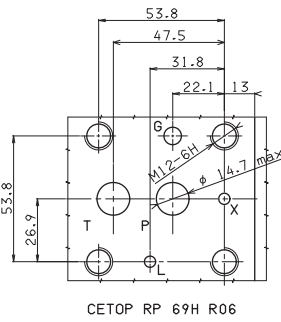

VERSION WITH
PRESETTING FOR
SOLENOID VALVE

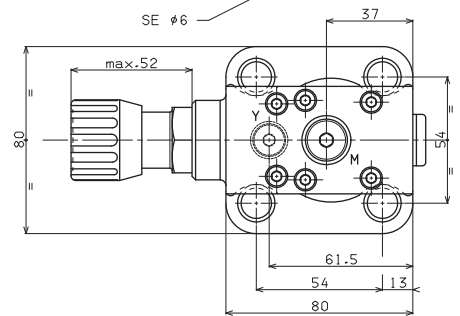
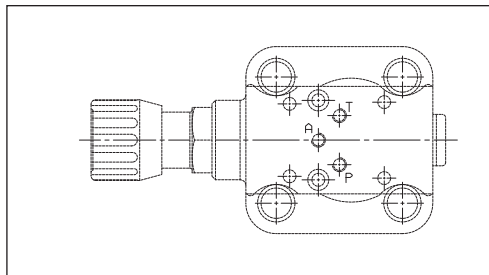

Fixing screws UNI 5931 M12x40 with material specifications min. 8.8
Tightening torque 70 Nm / 7 Kgm

M = 1/4" BSP connector for pressure gauge for maximum pressure valve version only
Y = 1/8" BSP external draining for sequencing valve version only

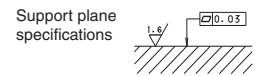

OVERALL DIMENSIONS V*.P.25...

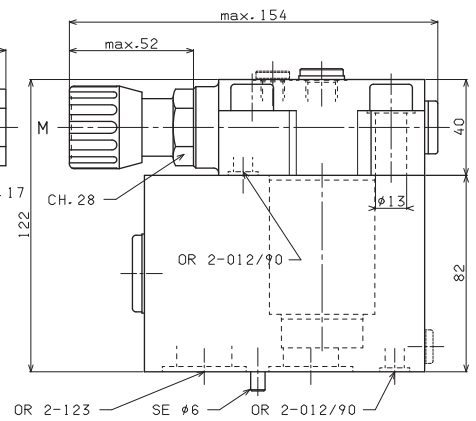
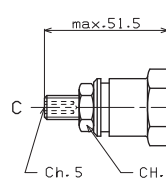
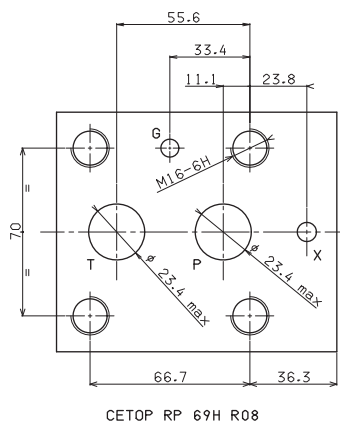

VERSION WITH
PRESETTING FOR
SOLENOID VALVE

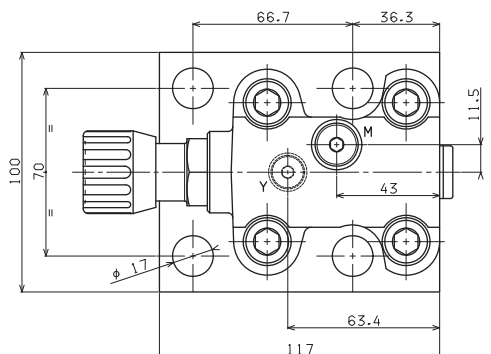
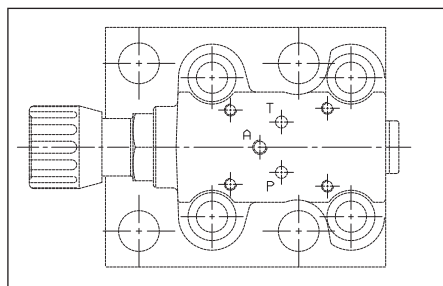

Fixing screws UNI 5931 M16x100 with material specifications min. 8.8
Tightening torque 70 Nm / 7 Kgm

M = 1/4" BSP connector for pressure gauge for maximum pressure valve version only
Y = 1/8" BSP external draining for sequencing valve version only

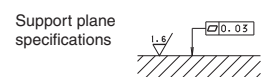

2

MOUNTING TYPE V*.P.E...

<p>V*.P.E... + AD.3.E.15.E... OR AD.3.E.16.E...</p> <p>1) Solenoid de-energized, pump to tank. 2) Solenoid energized, circuit pressure controlled by valve on cover. For mounting valves to have normally discharged configuration it is necessary to use an AD.3.E.15.F. or AD.3.E.16.F... type solenoid valve, whilst for subplate mounting valves it is necessary to use type AD.3.E.15.E... or AD.3.E.16.E.</p>		
<p>V*.P.E... + AD.3.E.15.F... OR AD.3.E.16.F...</p> <p>1) Solenoid de-energized, pump pressure controlled by valve on cover. 2) Solenoid B energized, pump to tank.</p>		
<p>V*.P.E... + AM.3.VM.B... + AD.3.E.15.E... OR AD.3.E.16.E...</p> <p>1) Solenoid de-energized, pump pressure controlled by valve on cover. 2) Solenoid energized, pump pressure controlled by valve AM.3.VM.B.</p>		
<p>V*.P.E... + AM.3.VM.B... + AD.3.E.02.C...</p> <p>1) Solenoid de-energized, pump to tank. 2) Solenoid A energized, pump pressure controlled by valve AM.3.VM.B. 3) Solenoid B energized, pump pressure controlled by valve on cover.</p>		
<p>V*.P.E... + AM.3.VM.B... + AD.3.E.01.C...</p> <p>1) Solenoid de-energized, pump pressure controlled by valve on cover. 2) Solenoid A energized, pump pressure controlled by valve AM.3.VM.AB. 3) Solenoid B energized, pump pressure controlled by valve AM.3.VM.AB.</p>		

OVERALL DIMENSIONS V*.L.16...

1/2" BSP P connector
3/4" BSP T connector

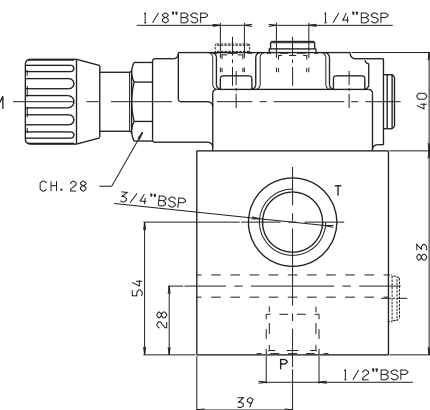
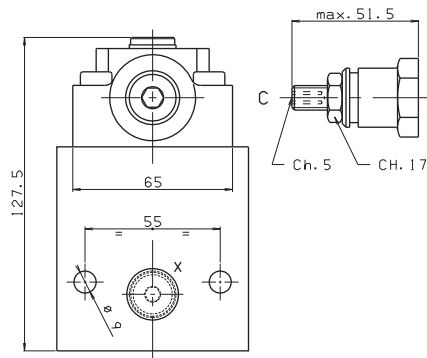

VERSION WITH PRESETTING FOR SOLENOID VALVE

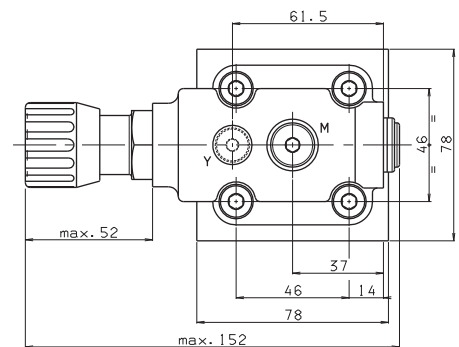
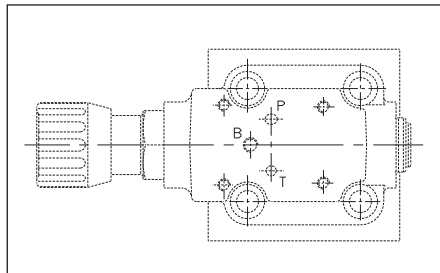

Fixing screws UNI 5931 M8x90 with material specifications min. 8.8
Tightening torque 24 Nm / 2.4 Kgm

M = 1/4" BSP connector for pressure gauge for maximum pressure valve version only
Y = 1/8" BSP external draining for sequencing valve version only

OVERALL DIMENSIONS V*.L.161...

3/4" BSP P and T connectors

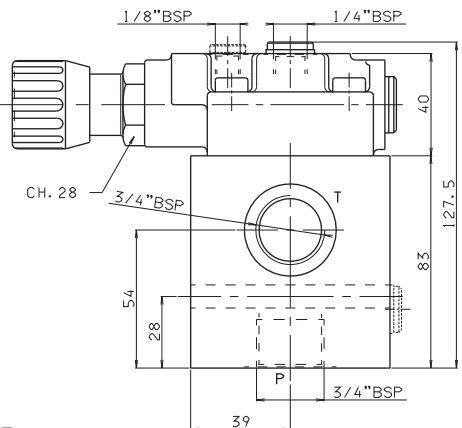
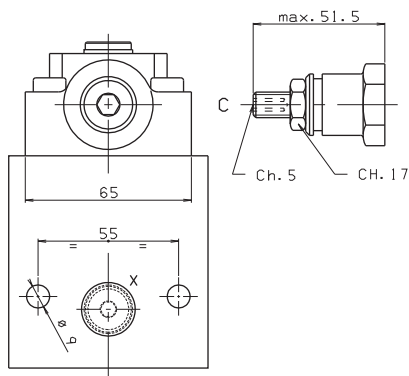

VERSION WITH PRESETTING FOR SOLENOID VALVE

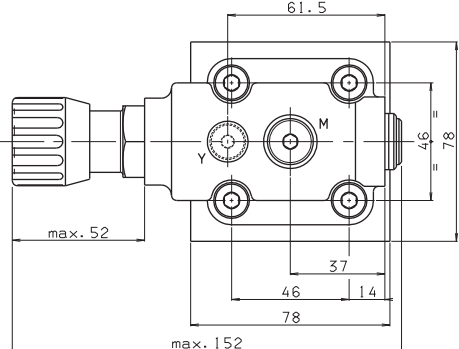
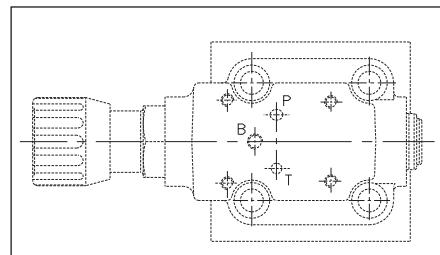

Fixing screws UNI 5931 M8x90 with material specifications min. 8.8
Tightening torque 24 Nm / 2.4 Kgm

M = 1/4" BSP connector for pressure gauge for maximum pressure valve version only
Y = 1/8" BSP external draining for sequencing valve version only

OVERALL DIMENSIONS V.*.L.25...

1" BSP P connector
1 1/4" BSP T connector

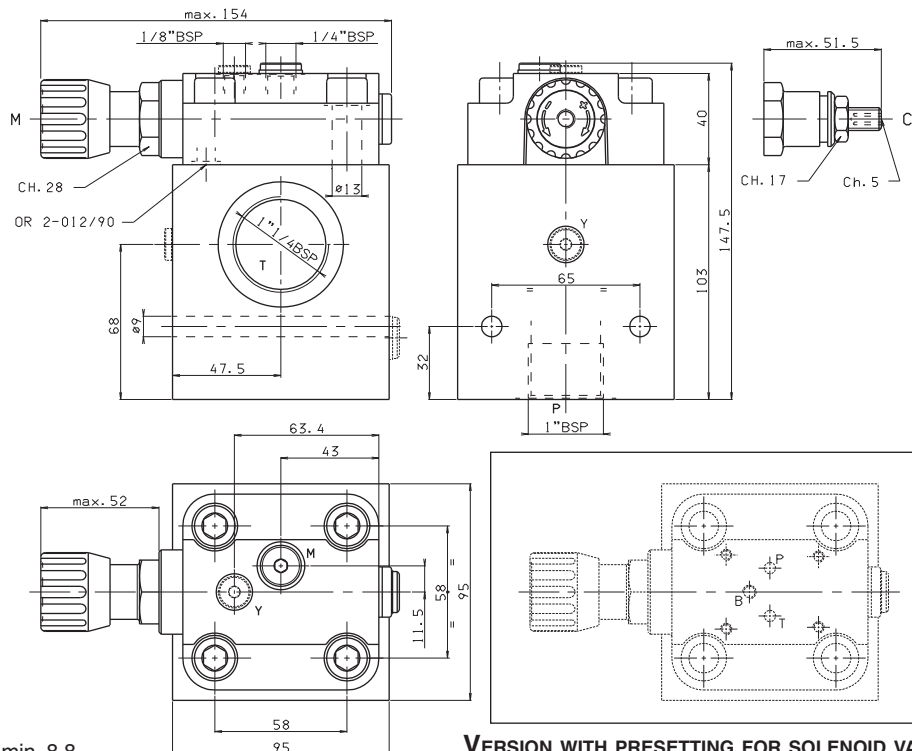

Fixing screws UNI 5931
M8x110 with material specifications min. 8.8
Tightening torque 24 Nm / 2.4 Kgm

M = 1/4" BSP connector for pressure gauge for maximum pressure valve version only
Y = 1/8" BSP external draining for sequencing valve version only

VERSION WITH PRESETTING FOR SOLENOID VALVE

OVERALL DIMENSIONS V.*.L.251...

1 1/4" BSP P connector
1 1/2" BSP T connector

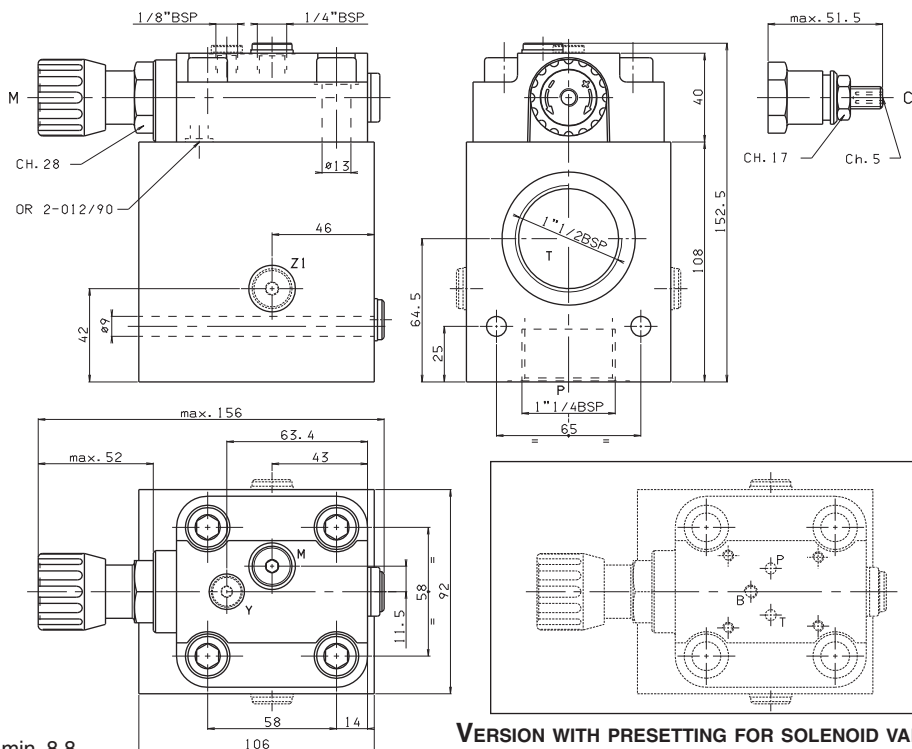

Fixing screws UNI 5931
M8x120 with material specifications min. 8.8
Tightening torque 24 Nm / 2.4 Kgm

M = 1/4" BSP connector for pressure gauge for maximum pressure valve version only
Y = 1/8" BSP external draining for sequencing valve version only

VERSION WITH PRESETTING FOR SOLENOID VALVE