

XEPV.3... PROPORTIONAL VALVE WITH ELECTRONIC ON BOARD

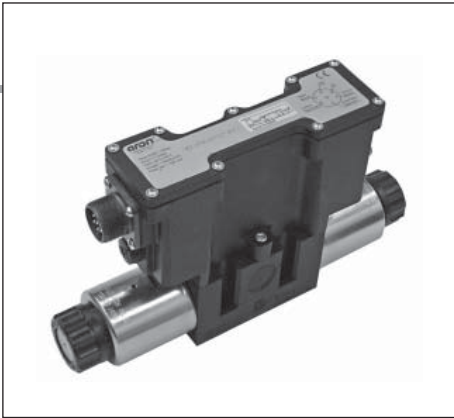

The proportional directional valves XEPV are designed as direct operated components for subplate mounting. They are actuated by means of proportional solenoids with central thread and removable coil. The solenoids are controlled by integrated control electronics.

Features:

- Integrated control electronics
- Setup parameters by CAN interface
- Current compensation, gain current and ramps setting
- Monitoring of the valve by real time scope interface

European norms: EN 61000 - ElectroMagnetic Compatibility (EMC) - industrial environment

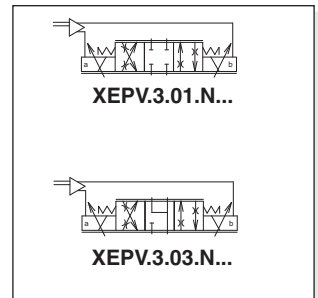

XEPV.3...	
AM.3.H...	CH. VIII PAGE 16
AM.5.H...	CH. VIII PAGE 17
BC.3.07...	CH. VII PAGE 12

ORDERING CODE

XEPV	Current loop proportional valve with integrated electronics 24Vdc
3	CETOP 3/NG6
**	Type of spool
01	spool with P, A, B and T ports, closed
03	spool with P port closed, and A, B, T ports connected
N	Symmetrical flow control
*	Flow rating at Δp 8 bar
0	4 l/min
1	8 l/min
2	15 l/min
3	25 l/min
6	36 l/min (we advise to use the hydrostat AM5H3VP108)
S	CAN bus communication S = standard ARON
*	Command Enable E = with external command Enable W = without external command Enable
*	Type command V = signal voltage $\pm 10V$ C = signal current 4... 20mA
00	No variants
1	Serial No.

INPUT SIGNAL CURVES - FLOW RATE

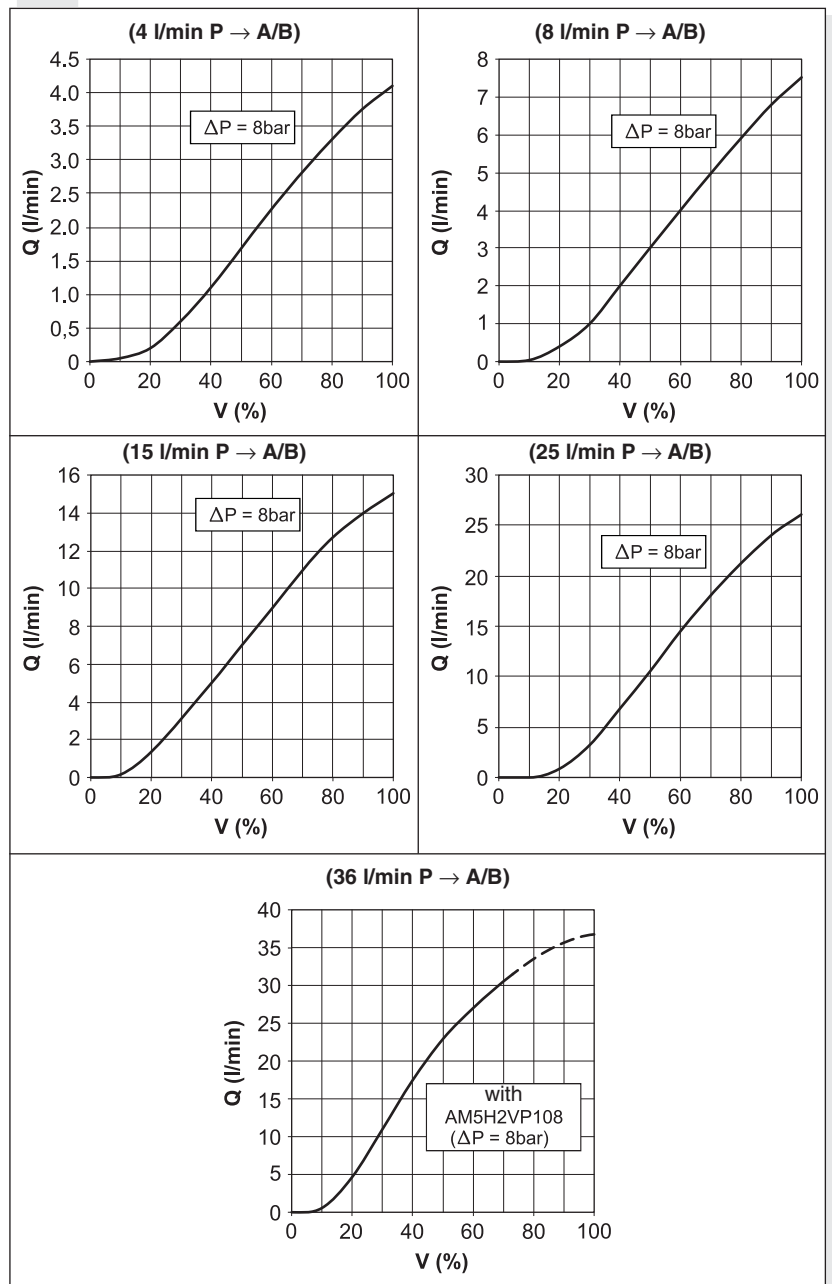

8

STEP RESPONSE ($\Delta p = 8 \text{ bar P/A}$)

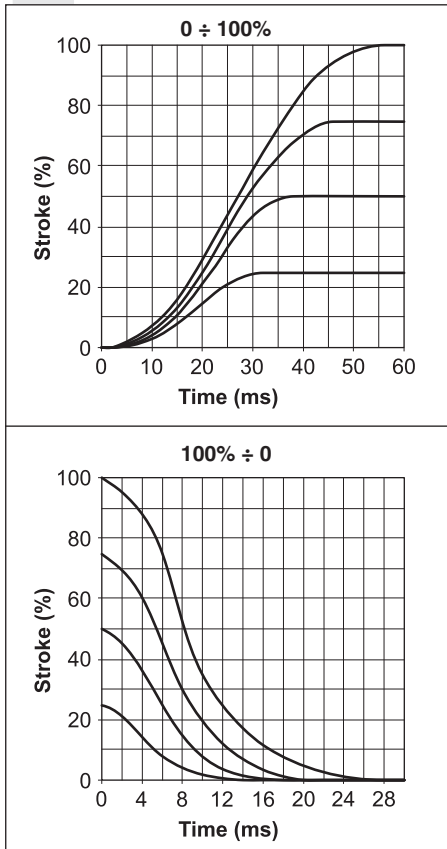

OPERATING SPECIFICATIONS OF VALVE WITH TRANSDUCER

Installation	must keep horizontal
Max. operating pressure ports P/A/B	350 bar
Dynamic pressure port T	210 bar
Static pressure port T	210 bar
Nominal flow	4 / 8 / 15 / 25 / 36 l/min
Performance curves	See diagrams
Fluid temperature	-20 ÷ 75°C (preferably 40 ÷ 50°C)
Fluid viscosity	10 ÷ 500 mm ² /s
Max. contamination level	class 7 to 9 in accordance to NAS 1638 with filter $\beta_{10} \geq 75$
Weight	2.45 kg
Nominal supply voltage	24Vdc
Input signal range (see ordering code)	± 10V or 4... 20mA
Supply voltage lower limit	18V
Supply voltage upper limit	36V
Peak power	50W
Max. coil temperature	150 °C
Duty cycle	Continuous 100% ED
Hysteresis	< 5%
Response sensitivity	< 0.5%
Repeatability	< 0.5%
Enable input command	0V = valve not active 24V = valve active
Fault signal output	0V = failure or not working valve 24V = valve OK
Current monitor	± 10V
Ambient temperature range	-20 ÷ 60°C
Type of protection	IP 65

Operating specifications are valid for fluids with 46 mm²/s viscosity at 40°C.

8

OVERALL DIMENSIONS

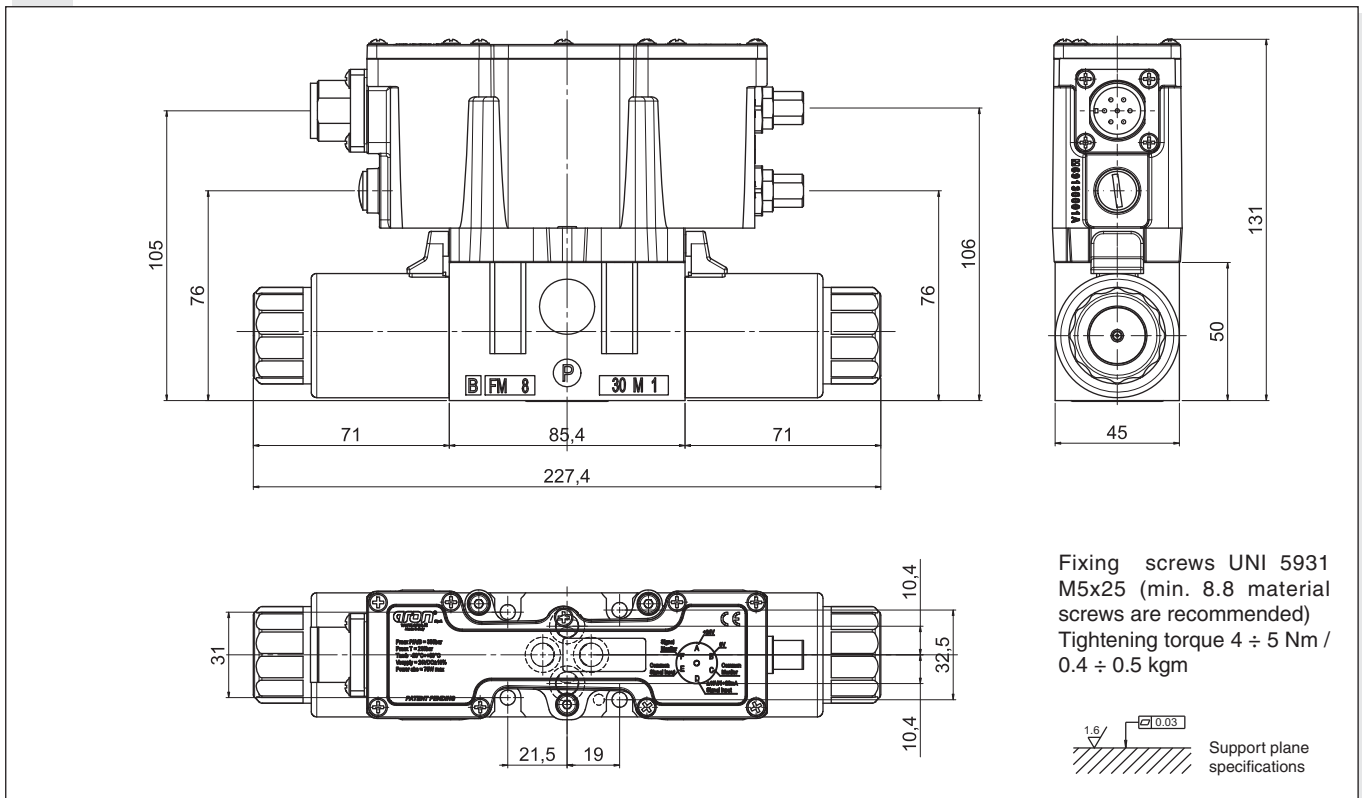

Fixing screws UNI 5931 M5x25 (min. 8.8 material screws are recommended) Tightening torque 4 ÷ 5 Nm / 0.4 ÷ 0.5 kgm



ELECTRICAL CONNECTIONS

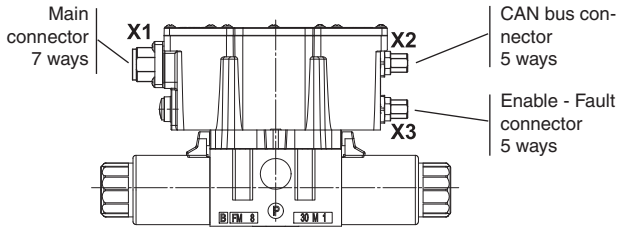

- A positive command value 0 to +10V (or 12 to 20mA) at D and the reference potential at E, results in a flow from P to A and B to T.
- A negative command value 0 to -10V (or 12 to 4mA) at D and the reference potential at E, results in a flow from P to B and A to T.

X2*: 5 ways M12 connector, CAN communication (to be ordered separately)

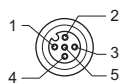

5 pole connector

5 ways connector code: VE0032700

IEC 61076-2-101 - 5 poles female

Type	PIN	Description
CAN data Aron interface	1	CAN_H
	2	CAN_L
	3	
	4	
	5	GND

* Connection cable recommended: up to 50m cable length type LiYCY 7x0.75 mm². For outside diameter see plug-in connector sketch. Only connect screen to PE on the supply side.

X1: Main connector 7 ways (supplied with the valve)

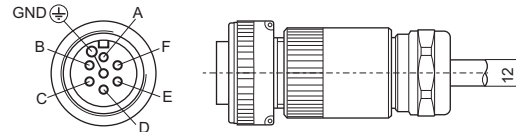

DIN EN 175201-804 - 7 poles female

Type	PIN	Description
Main power supply	A	+24Vdc
	B	0V / common supply
0V / common of signal monitor	C	0V / common of signal monitor
Input of differential signal command	D	± 10V or 4...20mA
	E	0V / common
Output of signal monitor	F	± 10V (10V = max current)
	GND	GND

Connection cable recommended: up to 50m cable length type LiYCY 7x1.0 mm². For outside diameter see plug-in connector sketch. Only connect screen to PE on the supply side.

X3*: 5 ways M12 connector, Enable and Fault digital command (to be ordered separately)



5 pole connector

5 ways connector code: VE0032700

IEC 61076-2-101 - 5 poles female

Type	PIN	Description
Digital output signal of valve FAULT	1	Connects to +24Vdc
	2	Signal out: 0V = failure of electronic control 24V = valve OK
Input digital command of ENABLE valve	3	Connects to 0V
	4	Connects to +24V to enable the valve
	5	

ARON SOFTWARE AND CABLES

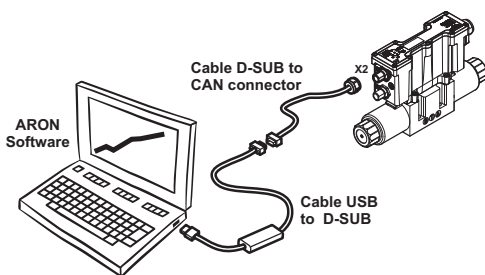

ADAPTER FOR PC: CABLE USB TO D-SUB



Model: KVASER Leaf light HS (not supplied, commercial parts)

ARON INTERFACE FOR SETUP PARAMETERS

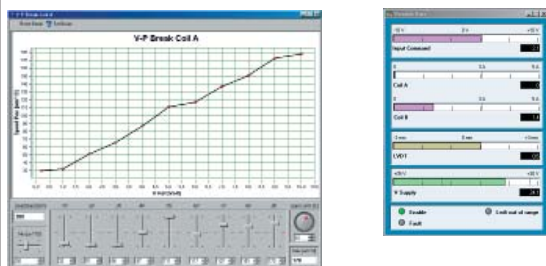

Aron Firetune software code: P35150005

For further information about Aron Firetune read the manual. The software is included with valve supply.

ADAPTER FOR PC: CABLE D-SUB TO CAN CONNECTOR

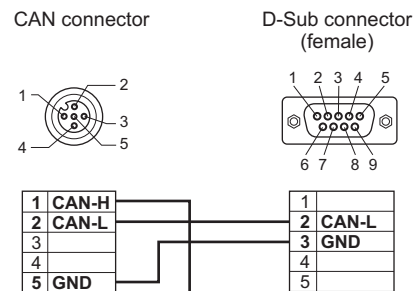

The cable and D-Sub connector are not supplied. Assemble the parts as shown in the diagram.